

OmniCure®
SC0750/SC1000/SC2000/SC3000
UV Curing Solutions

Applicable for the following System Controller models:

Model	Part Numbers
SC0750	019-00199R
SC1000	019-00186R
SC2000	019-00211R
SC3000	019-00213R

Installation/Reference Guide

Excelitas Canada Inc.
2260 Argentia Road
Mississauga (ON)
L5N 6H7 Canada
+1 905.821.2600
www.excelitas.com

035-00539R rev.5

OmniCure® SC- Series

UV Curing Solutions

Installation/Reference Guide

035-00539R

Excelitas Canada Inc. 2021

All rights reserved

No part of this publication may be reproduced, transmitted, transcribed, stored in a retrieval system or translated into any language in and form by any means without the prior written consent of Excelitas Canada Inc. every effort has been made to ensure information in this manual is accurate, however, information in this manual is subject to change without notice and does not represent a commitment on the part of the authors.

Trademarks:

OmniCure® is a trademark of Excelitas Canada Inc. All rights reserved. All other product names are trademarks of their respective owners. All product or software photos shown are for reference only and are subjected to change without notice.

Made in Canada. Doc. No. 035-00539R

www.excelitas.com/omnicure

Excelitas Canada Inc. 2021

All rights reserved

ii

035-00539R rev 5

Revision History

Revision #	Comments
Rev 1.0	Initial release
Rev 2.0	Updated corporate logo, minor edits/corrections
Rev 3.0	Added SC2000 and SC3000
Rev 4.0	Streamlined regulatory section
Rev 5.0	Update to regulatory section and website links

Table Of Contents

1	Introduction	1
2	Safety Precautions/ User Warnings	2
2.1	Glossary of Symbols:	2
3	Getting Started	3
3.1	Packaging Contents	3
4	Connecting the System Controller	4
5	Mounting the System Controller.....	6
5.1	Mechanical Dimensions.....	7
5.2	Electrical Connectivity.....	8
6	Troubleshooting	9
7	Care and Maintenance.....	11
8	Technical Specifications	12
8.1	Environmental and Unit Specifications	12
8.2	Regulatory Compliance	12
8.3	China RoHS.....	13
8.4	WEEE Directive (2012/19/EU)	13
9	Warranty.....	15
9.1	Returning your System Controller to Excelitas Technologies for Service	15
10	Contact Information	16

Figures

Figure 1	SC0750/SC1000/SC2000 Unit.....	4
Figure 2	SC3000 Unit.....	4
Figure 3	SC0750/SC1000/SC2000 Mechanical Dimensions	7
Figure 4	SC3000 Mechanical Dimensions.....	7
Figure 5	Power Connector (looking at System Controller).....	8

Tables

Table 1	Power Connector Pin Out.....	8
Table 2	Technical Specifications.....	12

1 Introduction

The OmniCure® SC0750/SC1000/SC2000/SC3000 System Controllers are designed to be used specifically with OmniCure® AC-Series UV LED systems. Designed to fit in a 1U rack, these System Controllers provide a compact solution for powering up to two AC-series products simultaneously. Operating over a universal input AC voltage range from a standard receptacle allows easy and quick installation without the need for dedicated electrical resources. The rear-mounted integrated electrical circuit breaker provides electrical fault protection and isolation while a front-mounted on/off switch and power indicator provides users with a simple, easy-to-access means of powering AC-series products on a day-to-day basis.

OmniCure® has combined next generation optical engineering, state-of-the art electronics and fibre-optics to produce sophisticated technologies that employ light. Today, OmniCure® is a leading developer of light-based systems for sectors ranging from manufacturing to bio-medical, and is unmatched in its commitment to quality and service.

This manual covers the following models:

SC0750	019-00199R
SC1000	019-00186R
SC2000	019-00211R
SC3000	019-00213R

Excelitas Technologies recommends reading this guide to discover all features of the OmniCure® SC0750/SC1000/SC2000/SC3000 System Controllers, and how to use them.

2 Safety Precautions/ User Warnings

NOTE: The SC Series PSU have been designed for safe use, however, if the equipment is used in a manner not specified by the manufacturer, the protection systems provided by the equipment may be impaired.

The safety of any system incorporating an SC Series PSU is the responsibility of the assembler of the system

2.1 Glossary of Symbols:



Caution risk of danger – consult accompanying documents.



Protective Conductor Terminal



Earth (Ground) Terminal



CAUTION, Risk of Electrical Shock

3 Getting Started

3.1 Packaging Contents

The package contains:

- One of the following System Controllers:
 - SC0750 019-00199R
 - SC1000 019-00186R
 - SC2000 019-00211R
 - SC3000 019-00213R
- AC power cable, selected for mains power receptacles in the destination country
- A small polythene bag containing mounting brackets (x2)
- Documentation CD
- Depending on the exact order, the package may also contain a DC power cable.

Carefully remove the contents and store the packaging materials for future use.

In addition to the System Controller enclosed, a functional UV curing setup will require:

- At least 1 DC power cable (for example, 018-00559R or 018-00595R – 5m power cable)
- At least 1 AC-series UV LED Head.

Before installation, ensure that the total DC electrical load does not exceed approximately 85% of the rating of the SC-series unit to be installed.

4 Connecting the System Controller

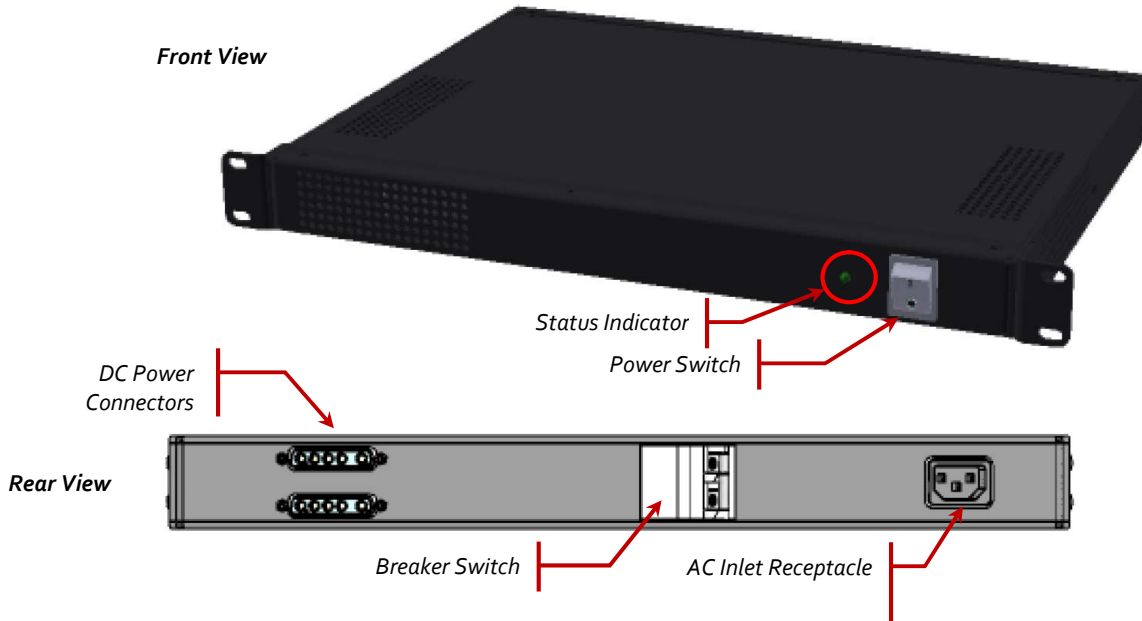

Figure 1 SC0750/SC1000/SC2000 Unit

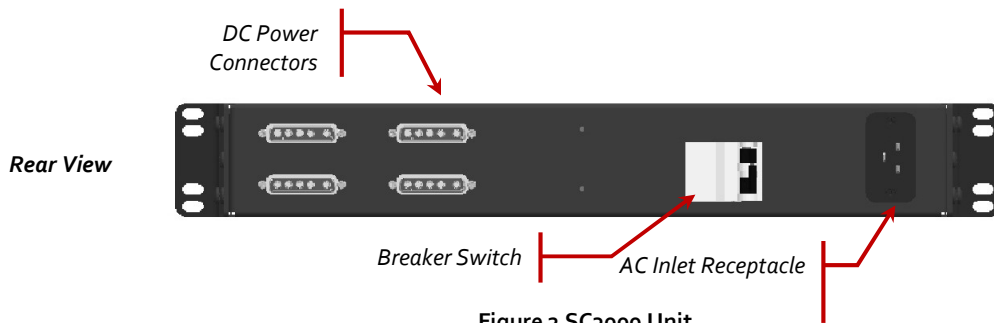

Figure 2 SC3000 Unit

1. Before any electrical connections are made, ensure that the electrical circuit breaker is tripped. This can be done by pushing the breaker switch away from the AC-inlet receptacle.
2. Ensure that the power switch on the front of the System Controller is set to the "off" position.
3. Locate the AC power cord and insert into the AC-inlet receptacle on the rear of the System Controller.
4. Locate the pair of 5W5 DC power connectors on the rear of the System Controller. Connect the DC cable and tighten the jack screws to prevent the connector disengaging during use.
5. Connect the other end of the cable to the UV LED head and tighten the jack screws as before.
6. Connect any other control cabling to the UV LED head as required and as per the specific product manual for that system.

OmniCure® SC- Series

UV Curing Solutions

7. If the System Controller is intended to power more than one UV LED head, repeat steps 5 and 6 for each unit to be connected.
8. Plug the trailing end of the AC power cord into an AC mains outlet at the wall capable of supplying voltage and current as per the specifications in this manual.
9. Arm the circuit breaker by pushing the breaker switch towards the AC-inlet receptacle.
10. Using the power switch on the front of the System Controller, power on the connected AC-series UV LED equipment. When the outputs are live, a green LED status indicator on the front of the System Controller will be lit. The internal power supply circuitry is now energized and the internal fan should now be audible.
11. If the status indicator does not illuminate and the UV LED heads fail to power up, ensure that steps 1-9 have been followed properly.



****WARNING****

The System Controller should only be connected to a mains outlet using the style and rating of cable provided. This regional cable is of the 3-pin variety and carries a protective earth connection. For user safety, do not substitute this cable with any 2-pin variety.

5 Mounting the System Controller

The SC0750, SC1000 and SC2000 share the same mechanical chassis, while the SC3000 has a slightly larger mechanical enclosure. However, the mounting instructions apply equally to all models with the exception of mounting hole locations.

It is recommended that the System Controller be carried by holding the unit on two opposite sides, with fingers supporting the underside of the unit. During installation, the unit is light enough to be balanced in one hand, leaving the other hand free for inserting mounting screws. If access is restricted or the installer prefers a different approach, supporting the underside of the unit at approximately the level height of the installation location using a suitable mechanical prop would also suffice.

While the System Controller can be left as a free-standing unit, it is intended to be easily installed in well-ventilated 19" rack-mounting. It is recommended that the System Controller be installed with the text on the labels oriented the right way up.

To install the System Controller in a 19" rack:

1. Disconnect any electrical cables that are connected to the main chassis.
2. Remove the two mounting brackets from the polythene bag.
3. Locate the four screws on the sides of the enclosure towards the front and remove.
4. The mounting bracket has two slots and two holes. The holes are intended for attachment of the brackets to the main chassis. Using two of the removed screws, attach the mounting bracket to the side of the enclosure.
5. Using the two remaining screws, repeat step 4 for the other side of the enclosure. The enclosure is now ready to be mounted in the rack.
6. Identify a screw-hole pair in the rack that lines up with the holes in the mounting brackets and using a screw-type compatible with the rack threading (usually #10-32 (imperial) or M4 (metric)), thread a single screw into one of the two holes and tighten by hand.
7. Supporting the foremost underside of the unit, move to the other side of the chassis and level the front of the enclosure. Insert another screw into one of the two holes and tighten by hand.
8. Move the support to the rear of the enclosure and raise the support until the front-back direction is level. Insert an additional screw into the mounting bracket on each side. The unit should now be in approximately the final intended lateral position.
9. Adjust the position of the unit (if necessary) to finalize location. The mounting bracket face that mates with the rack is slotted to allow some adjustment.
10. When satisfied with the position, tighten the four mounting screws using a screwdriver. Do not over-tighten as this may strip the threading in the rack and render the mounting location useless.

Note: The mounting brackets are designed to support the mechanical load of the System Controller chassis only. They are not designed to support any additional weight placed onto the top of the unit. Placing additional mechanical loading onto the unit may damage the mounting brackets, the racking or the mounting screws themselves. *Excelitas Technologies considers evidence of such cases as outside of warranty.*

It is recommended that both AC and DC-side cabling be tied off and mechanically supported to prevent undue stress on the electrical connectors.

Warning: This device includes a circuit breaker located on the rear panel, do not position the equipment so that it is difficult to operate the disconnecting device

5.1 Mechanical Dimensions

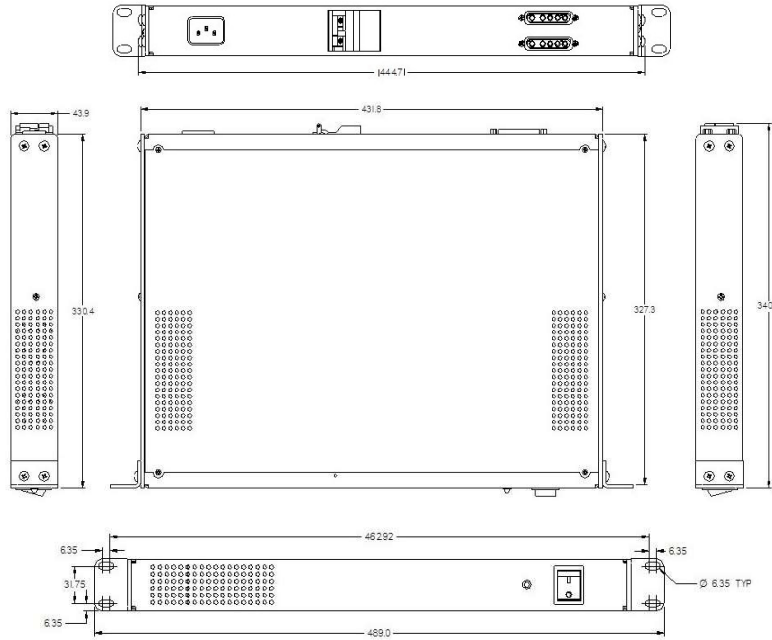

Figure 3 SC750/SC1000/SC2000 Mechanical Dimensions

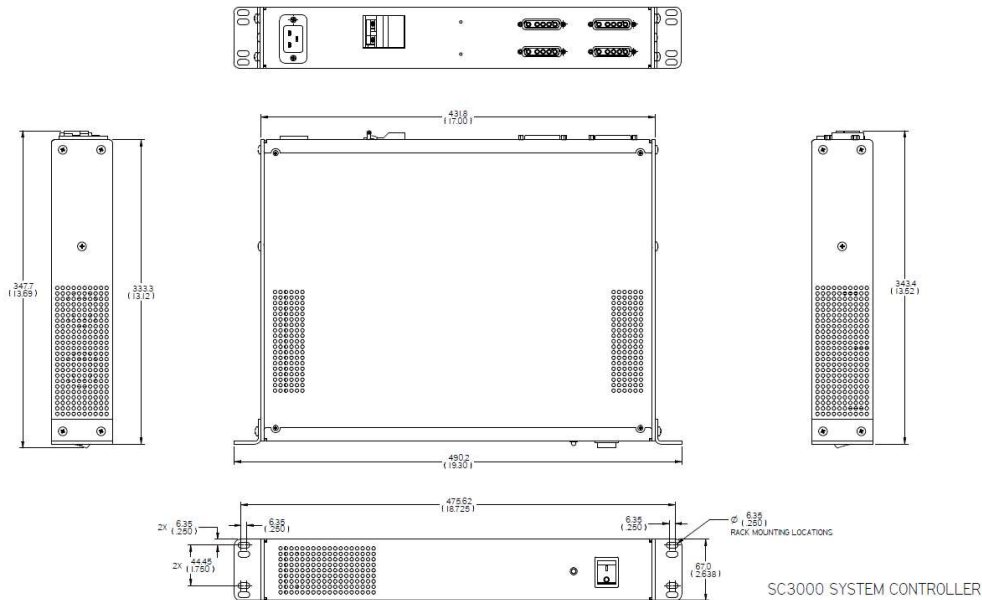

Figure 4 SC3000 Mechanical Dimensions

5.2 Electrical Connectivity

DC Power Connectors (x2)

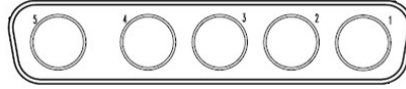

Figure 5 Power Connector (looking at System Controller)

PIN	Name	Description
A1	+ve	48V DC power feed.
A2	+ve	48V DC power feed. (SC2000 & SC3000 only. Shared current through this pin)
A3	-ve	48V DC power return.
A4	-ve	48V DC power return. (SC2000 & SC3000 only. Shared current through this pin)
A5	Chassis	Chassis ground connection

Table 1 Power Connector Pin Out

AC Power Connectors

SC0750/SC1000



SC2000/SC3000



6 Troubleshooting

Service to be completed by qualified Excelitas Technologies personnel only!

If the green LED indicator fails to illuminate:

- Validate that main voltage is reaching the receptacle intended for use by powering an independent electrical load from it, (e.g. a light).
- Check that the AC mains cable is connected securely to the AC mains and AC inlet receptacle on the SC-series unit.
- Ensure that the circuit breaker is set to the “armed” position.
- Ensure that the front panel on/off switch is set to the on position.
- If the indicator LED remains unlit, try disconnecting the DC-side cables and repeating steps 1-4. This will isolate the fault, if any, to the supply or the downstream connectivity.

If the UV LED heads are running and then power appears to be disconnected from them:

- Ensure that the combined electrical load from the connected AC-series heads is a supported configuration for the System Controller employed.
- Ensure that there is adequate ventilation for air intake and exhaust. If the System Controller is installed in a cabinet, the ambient temperature must be less than 40 degrees Celsius.

If the UV LED heads appear to be running at a reduced intensity:

- Verify that the AC mains voltage for the SC0750 and SC1000 is within the range of 100-240V AC @50/60Hz. Of particular concern is the low end AC voltage.
- Verify that the AC mains voltage for the SC2000 and SC3000 is within the range of 200-240V AC @50/60Hz. Of particular concern is the low end AC voltage.



1: Inspect the AC cable for any signs of wear or mechanical damage. If any point along the cable is damaged, contact [Excelitas Technologies](https://www.excelitas.com) Service department for replacement (refer to Section 6, please make a note of the problem encountered, the steps followed to isolate the problem and the result of any trouble shooting steps taken).

Telephone the nearest Excelitas Technologies Service Centre to obtain a Return Authorization Number so that repairs may be completed quickly and efficiently. In North America, request for Return Authorization number can be made online at https://www.excelitas.com/ox_service_request_form

Enclose details of the problem with the unit and return both to the Excelitas Technologies Service Centre. The unit should be returned in its original packaging if possible.

Include a phone number and contact person who may be reached for any additional service-related questions.

Contact Information”).

- Verify that the DC voltage at the point of load is greater than 47V.



Caution: Inspect the DC cable(s) for any signs of wear or mechanical damage. If any point along the cable looks damaged, contact [Excelitas Technologies](https://www.excelitas.com) Service department for replacement.

OmniCure® SC- Series

UV Curing Solutions



Caution: It is normal for electrical cables and connectors to warm up while in use. If a cable or connector is too hot to be comfortably handled, there may be an electrical problem associated with it. Contact [Excelitas Technologies](https://www.excelitas.com) Service department for guidance.

7 Care and Maintenance

The System Controllers are designed to provide years of trouble-free operation with little maintenance activity. Here are some guidelines for ensuring long-life from the System Controller.

- Do not locate the System Controller directly in an environment with air-borne contamination. If the unit needs to be in such an environment, install inside a ventilated cabinet with fan-assisted air-filtration. Observe the air flow direction of the SC-series (left to right) relative to the cabinet and configure the cabinet accordingly.
- Ensure all air-intakes and exhaust vents are at least 50mm away from obstruction and free from dust and debris. If necessary, wipe with a dry cloth or use compressed air to dislodge particulate matter which may be stuck to the vents.



Caution: Do not use a wet cloth or any aerosol-type cleaning fluids as this may be ingested by the unit, causing damage and the risk of electrical shock.

- If the unit needs to be cleaned more thoroughly, first disconnect from the AC mains. Using a damp cloth (impregnated with either with water or alcohol), wipe the surfaces of the unit. Take care to ensure that the cloth is not dripping. If using alcohol, avoid the labels to prevent them from being smeared or detaching from the unit and avoid heavy rubbing. Do not use acetone.
- Ensure that AC-side and DC-side cables are connected firmly to the chassis and (where possible) screwed in to prevent damage to the connectors. Cables should be tied off to provide strain relief to the electrical connectors.
- Do not use the electrical breaker as the means to turn on/off power on a regular basis. The switch on the front of the unit is designed for more on-off cycles. The breaker should be set once when the system is commissioned and only reset if it trips at a later date.

8 Technical Specifications

8.1 Environmental and Unit Specifications

	SC0750	SC1000	SC2000	SC3000	
Operating Temperature Range (degrees C)	10-40C				
Relative Humidity	10-80% (non-condensing)				
Dimensions (mm) (not including mounting brackets)	Length	341			
	Depth	445			
	Height	44		67	
Weight (kg)	3.9kg (8.61 lbs)		4.22kg (9.3 lbs)	6.5kg (14.3 lbs)	
Input Voltage	100-240V AC 50/60Hz		200-240 AC 50/60Hz	200-220 AC 50/60Hz	220-240 AC 50/60Hz
Maximum AC input current (A)	9-4.3	12-6.5	13-9.6	15.6-13	
Circuit Breaker Rating	10	13	16A		
Maximum DC power (W)	750	1000	1992	2400	2700
DC output voltage	48V, +/-1V				
Maximum DC current (A)	15.7	21	41.5	50	56.3
Number of DC output connectors	2			4	
Certifications	CE, RoHS, WEEE				

Table 2 Technical Specifications

8.2 Regulatory Compliance

The SC0750/SC1000/SC2000/SC3000 System Controllers have been tested and found to comply with product safety and electromagnetic compatibility requirements. For a complete list of tests and for certification details, please contact your OmniCure® representative or visit www.excelitas.com/omnicure for more details.



****WARNING****

Changes or modifications not expressly approved by Excelitas Technologies could void the user's authority to operate the equipment.

Product Safety:

General Requirements

IEC Equipment Class: I
Installation Category: II
Pollution Degree: 2

Requirements for MAINS cords or cord sets are contained in ANSI/UL 817 and CSA C22.2 No. 21.

Requirements for general use receptacles, attachment plugs, and similar wiring devices are contained in ANSI/UL 498 and CSA C22.2 No. 42, CSA C22.2 No. 182.1, CSA C22.2 No. 182.2, and CSA C22.2 No. 182.3.

For Canadian and United States standards for MAINS connectors:

www.excelitas.com/omnicure

Excelitas Canada Inc. 2021

All rights reserved

OmniCure® SC- Series

UV Curing Solutions

Requirements for plugs of MAINS cords are contained in ANSI/UL 498 and CSA C22.2 No. 42, CSA C22.2 No. 182.1, CSA C22.2 No. 82.2, and CSA C22.2 No. 182.3.

CE Marking:

Council Directive 2014/35/EU	Low Voltage	
Council Directive 2014/30/EC	EMC	
Council Directive 2012/19/EU	WEEE	
Council Directive 2011/65/EU as amended by (EU) 2015/863	RoHS	

This is a class A product. In a domestic environment, this product may cause radio interference in which case the user may be required to take adequate measures.

FCC Class A Digital Device or Peripheral - Information to User

Note: This equipment has been tested and found to comply with the limits for a Class A digital device, pursuant to Part 15 of the FCC Rules. These limits are designed to provide reasonable protection against harmful interference when the equipment is operated in a commercial environment. This equipment generates, uses, and can radiate radio frequency energy and, if not installed and used in accordance with the instruction manual, may cause harmful interference to radio communications. Operation of this equipment in a residential area is likely to cause harmful interference in which case the user will be required to correct the interference at their own expense.



****WARNING****

Changes or modifications not expressly approved by Excelitas Technologies could void the user's authority to operate the equipment.

8.3 China RoHS



The symbol above indicates a product does not contain any restricted substances.

8.4 WEEE Directive (2012/19/EU)



The symbol above indicates that this product should not be disposed of along with municipal waste, that the product should be collected separately, and that a separate collection system exists for all products that contain this symbol within member states of the European Union.

www.excelitas.com/omnicure

Excelitas Canada Inc. 2021

All rights reserved

OmniCure® SC- Series

UV Curing Solutions

The equipment that you bought has required the extraction and use of natural resources for its production. It may contain hazardous substances that could impact health and the environment.

In order to avoid the dissemination of those substances in our environment and to diminish the pressure on the natural resources, we encourage you to use the appropriate take-back systems. Those systems will reuse or recycle most of the materials of your end life equipment in a sound way.

The crossed-out wheeled bin symbol indicated above invites you to use those systems.

If you need more information on the collection, reuse and recycling systems, please contact your local or regional waste administration.

9 Warranty

Excelitas Technologies warrants the original purchaser for a period of one (1) full year, calculated from the date of purchase, that the equipment sold is free from defects in material and workmanship.

In the event of a claim under this warranty, the equipment is to be sent postage and carriage paid to the [Excelitas Technologies Service Centre](#). Returned equipment will not be received without a Return Authorization (RA) Number, issued by the appropriate Service Centre.

In order for us to serve you better, include a written description of the fault and the name and telephone number of a contact person who may be contacted for additional service related questions.

Any claims for units received with defects in material or workmanship must be reported to an authorized Excelitas Technologies Service Centre within 30 days from the original date of receipt and returned within 30 days of reporting to an authorized Excelitas Technologies Service Centre. Excelitas Technologies will repair or replace these reported defects free of charge. The equipment must be sent postage and carriage paid.

Package the equipment in its original shipping case or as appropriate to prevent damage during transport.

In the case of damage caused by wear and tear, careless handling, neglect, by the use of force or in the case of interventions and repairs not carried out by an Excelitas Technologies Authorized Service Centre, the warranty ceases to be valid. This warranty may not form the basis for any claims for damages, in particular not for compensation of consequential damages.

This warranty is not transferable.

9.1 Returning your System Controller to Excelitas Technologies for Service

Please make a note of the problem encountered, the steps followed to isolate the problem and the result of any trouble shooting steps taken.

Telephone the nearest Excelitas Technologies Service Centre to obtain a Return Authorization Number so that repairs may be completed quickly and efficiently. In North America, request for Return Authorization number can be made online at https://www.excelitas.com/ox_service_request_form

Enclose details of the problem with the unit and return both to the Excelitas Technologies Service Centre. The unit should be returned in its original packaging if possible.

Include a phone number and contact person who may be reached for any additional service-related questions.

10 Contact Information

Excelitas Canada Inc.
2260 Argentia Road
Mississauga, Ontario
L5N 6H7 CANADA

Tel.: +1 905 821-2600

Toll: +1 800 668-8752 (USA and Canada)

Fax: +1 905 821-2055

<http://www.excelitas.com/Pages/Product/OmniCure.aspx>

www.excelitas.com/omnicure

Technical Assistance:

techsupport@excelitas.com

https://www.excelitas.com/ox_service_request_form

For a complete listing of Authorized OmniCure Distributors and Service Centres please go to

<https://www.excelitas.com/dealer-search>